

MCU

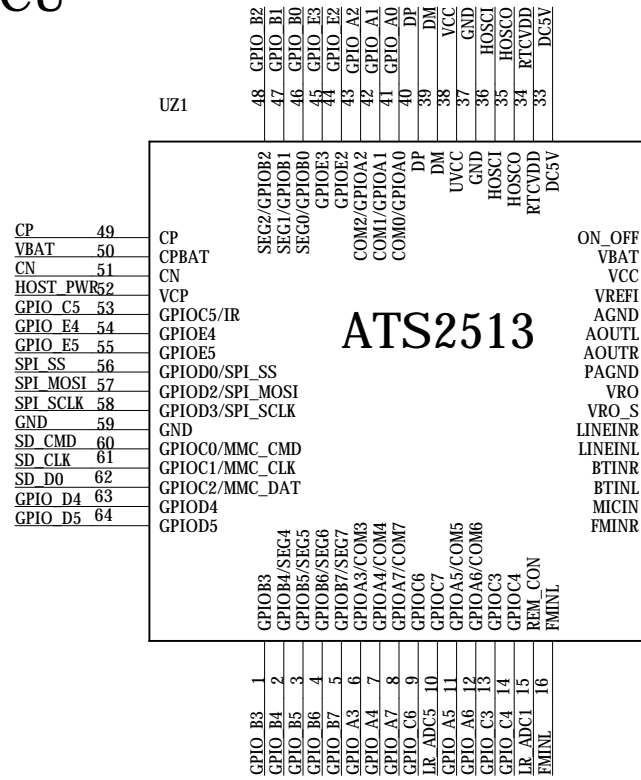

NOTE:
DC5V only detect PIN, not power supply PIN.
VBAT is the only power supply PIN.

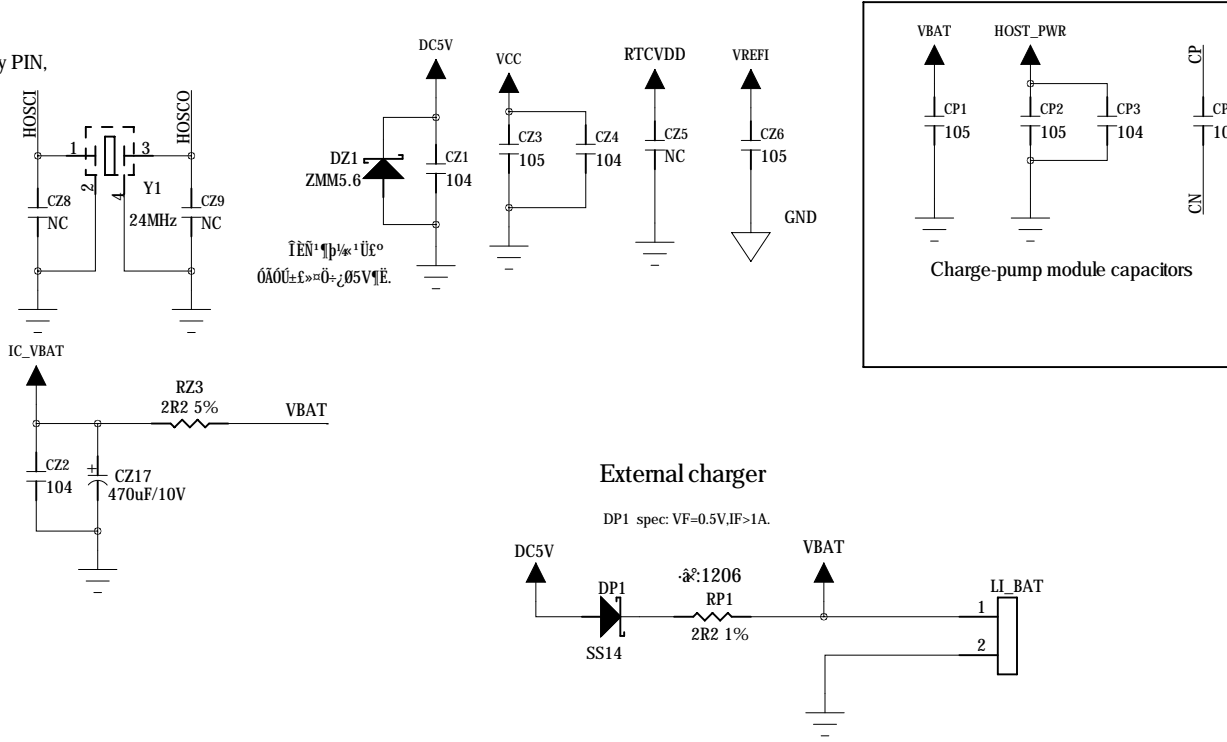

CON

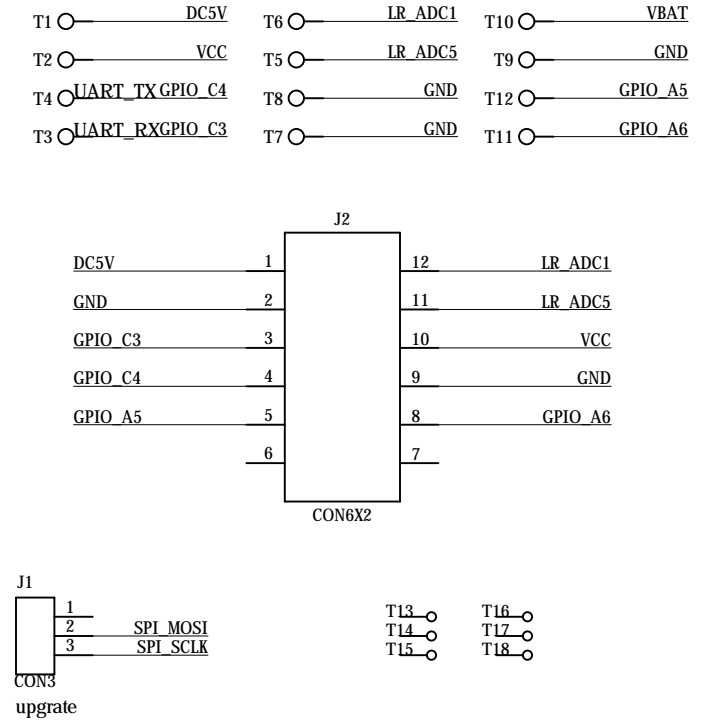

NOR

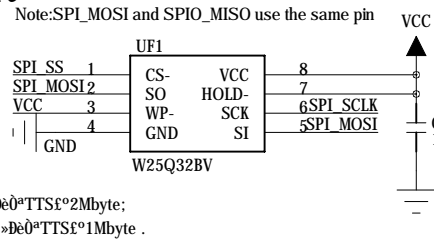

LED

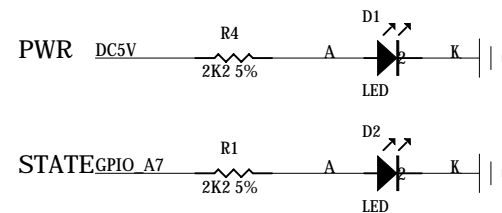

CARD

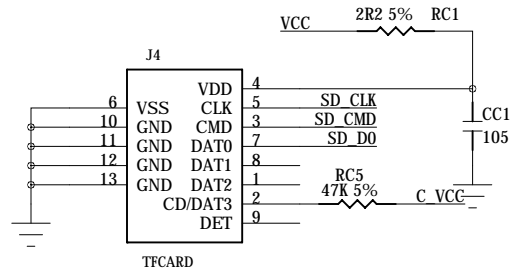

ENCRYPTION

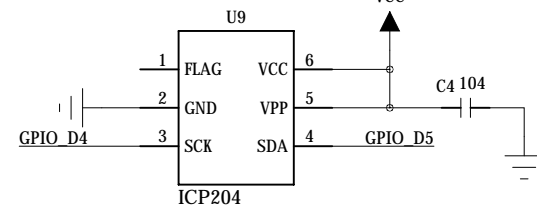

PA

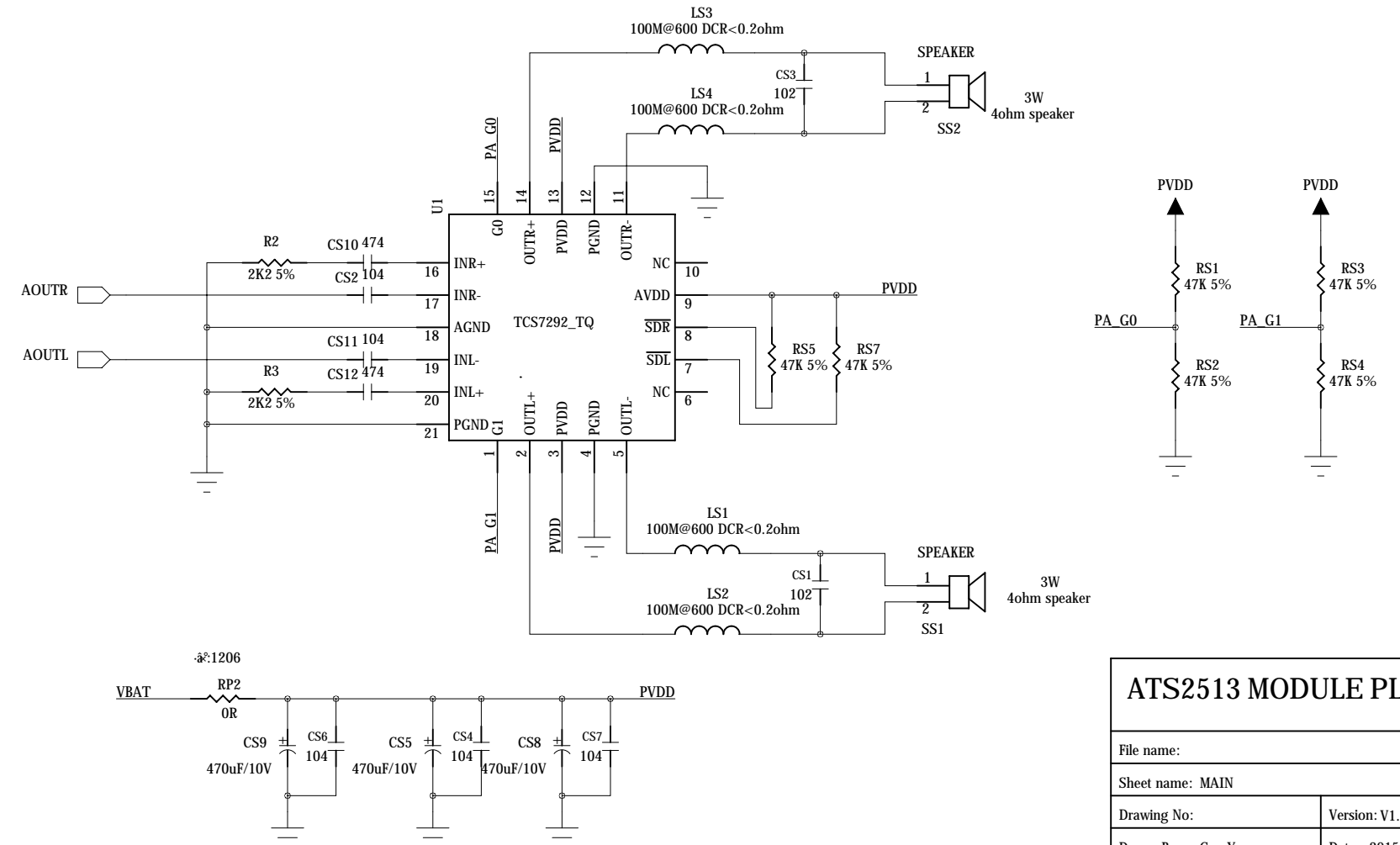

USB

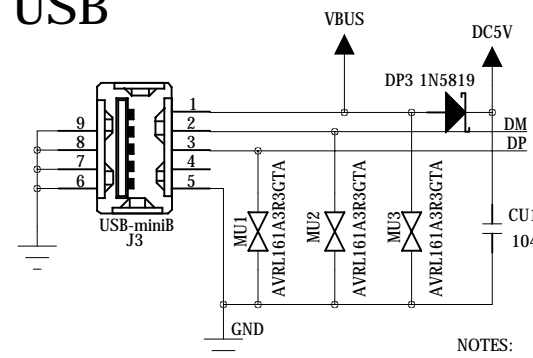

ON/OFF & RST

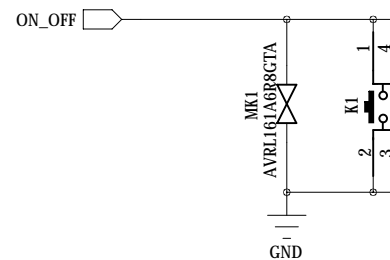

NOTES:

- (1) The capacitance of M1U/M2U must not be higher than 3pF.
- (2) J11's metal Shield must be connected to GND.
- (3) BU1/CMU1/CU1-CU4 are reserved for EMI, delete them if the EMI is ok.

ATS2513 MODULE PLAYER

File name:	
Sheet name: MAIN	
Drawing No:	Version: V1.0
Drawn By: GaryY	Date: 2015-11-01
Checked By:	Date:
Approved By:	Date:
Size: A3	Sheet: 3 of 3