

37GB-3530-EN MOTOR

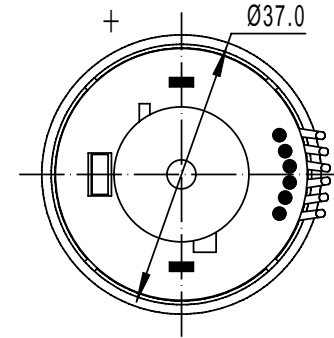
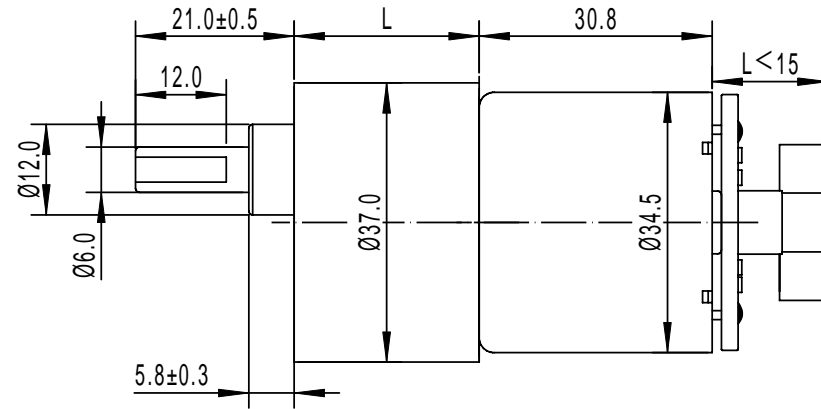
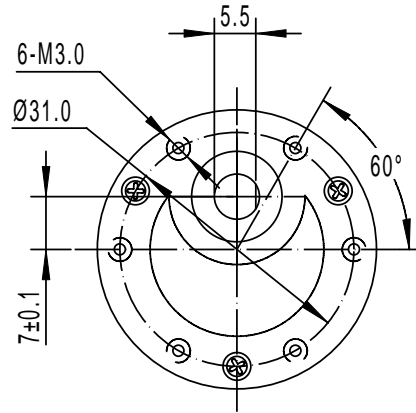

ELECTRICAL CHARACTERISTICS

| CHARACTERISTICS | SYMBOL | TEST CONDITIONS | MIN. | REF. | MAX. | UNITS |
|-----------------|--------|---------------------|------|------|------|-------|
| Input Voltage | Vcc | --- | 4.5 | -- | 24 | V |
| Output Current | Ice | Vcc=12V; Gauss<-170 | -- | 0.1 | 20 | mA |

Two Channel Encoder
 Connections:
 1、 Black : -motor
 2、 Red : +motor
 3、 Blue : HALL SENSOR Vcc
 4、 Green : HALL SENSOR GND
 5、 Yellow : HALL SENSOR A Vout
 6、 White: HALL SENSOR B Vout

| | | | |
|-----------------|------------------|------------------------|----------------------------------|
| TITLE:37GB-3530 | Customer No: | Drafted By: kevin wang | |
| | | Checked By: | |
| Dwg. NO: | Date: 2013.06.13 | Approved By: | |
| | | Scale: 1:1 | Units: mm |
| 深圳市国领微特电机有限公司 | | EDITION No: A | Angular: =1° Decimal: X.XX ±0.05 |
| | | | X.X ±0.2 |
| | | | X ±0.3 |

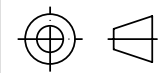

1
 2
 3
 4
 5
 6